

| Left Side Compartmentation  |         |                    |                   |            |
|-----------------------------|---------|--------------------|-------------------|------------|
| Compt                       | Doors   | Opening Dimensions | Inside Dimensions | Volume     |
|                             |         |                    | <b>WxHxD</b>      |            |
| L1                          | Roll Up | 24x62              | 31x72x27.25       | 35.2 CU FT |
| L2                          | Roll Up | 57x28              | 64x38x27.25       | 38.4 CU FT |
| L3                          | Roll Up | 46x62              | 53x72x27.25       | 60.2 CU FT |
| Right Side Compartmentation |         |                    |                   |            |
| Compt                       | Doors   | Opening Dimensions | Inside Dimensions | Volume     |
| R1                          | Roll Up | 24x23              | 31x33x27.25       | 16.1 CU FT |
| R2                          | Roll Up | 46x23              | 53x33x27.25       | 27.6 CU FT |
| Rear Compartmentation       |         |                    |                   |            |
| Compt                       | Doors   | Opening Dimensions | Inside Dimensions | Volume     |
| A1                          | Roll Up | 38x22              | 42x32x28.5        | 22.2 CU FT |

Total Volume  
199.6 CU Ft

Hale Qmax 1500 single stage  
Water Tank Capacity 750 gal  
Foam Tank Capacity 20 gal

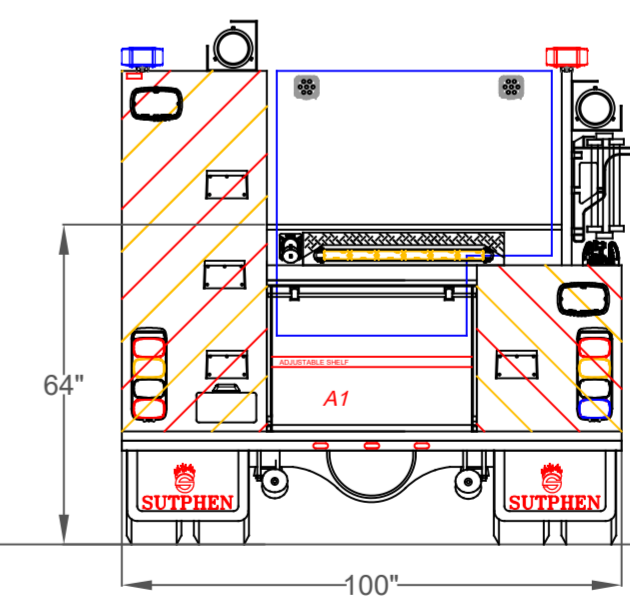
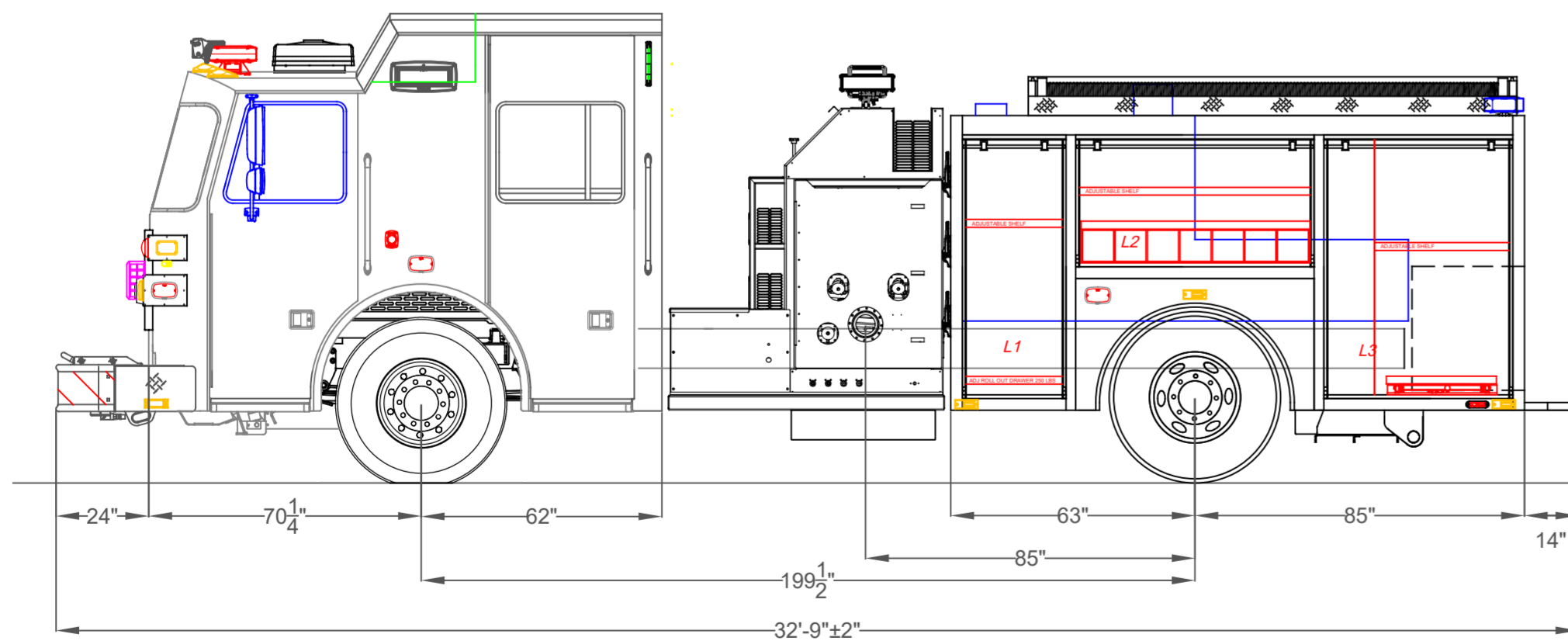

|   |                   |              |   |                        |   |
|---|-------------------|--------------|---|------------------------|---|
| DIMENSIONS SHOWN ON THIS DRAWING ARE APPROXIMATE AND ARE SUBJECT TO MINOR DEVIATIONS DURING CONSTRUCTION.<br><br>IN THE EVENT OF A DISCREPANCY BETWEEN THE SUTPHEN SPECIFICATIONS AND DRAWING, THE SUTPHEN SPECIFICATIONS SHALL PREVAIL.<br><br>DRAWING IS FOR REFERENCE ONLY. SOME ITEMS PROPOSED MAY NOT BE SHOWN OR NOTED. | CUSTOMER APPROVAL |              | REV. _____ DESCRIPTION _____ BY _____ DATE _____<br><br>THIS PRINT IS PROVIDED ON A RESTRICTED BASIS AND IS NOT TO BE USED IN ANY WAY DETRIMENTAL TO THE INTEREST OF SUTPHEN CORPORATION. | DRAWN BY:<br>J. GORDON | SUTPHEN EAST<br>55 INNOVATION DRIVE<br>LAKE ARIEL, PA<br>1-844-776-2889<br><br>NORTH POLE FIRE CO. INC.<br>WATERTOWN, NY<br><br>CUSTOM PROGRAM 2 ALUMINUM PUMPER<br><br>DWG. NO.: HS 6793 |
|   | NAME: _____       | TITLE: _____ |   | DATE: _____            |   |
| DATE: _____   |                   |              | MFG. FACILITY:<br>SUTPHEN EAST<br>LAKE ARIEL, PA  |                        |   |